

®
EVERGREEN PUMP DIMENSIONS
 (3450 RPM) SINGLE AND DUPLEX

For Quotations Please Contact Keystone Steam Supplies
 Call 905-361-0270 or email us at sales@keystonesteamsupplies.com

STANDARD CONTROL PANEL IS 12"W X 12"H X 6"D

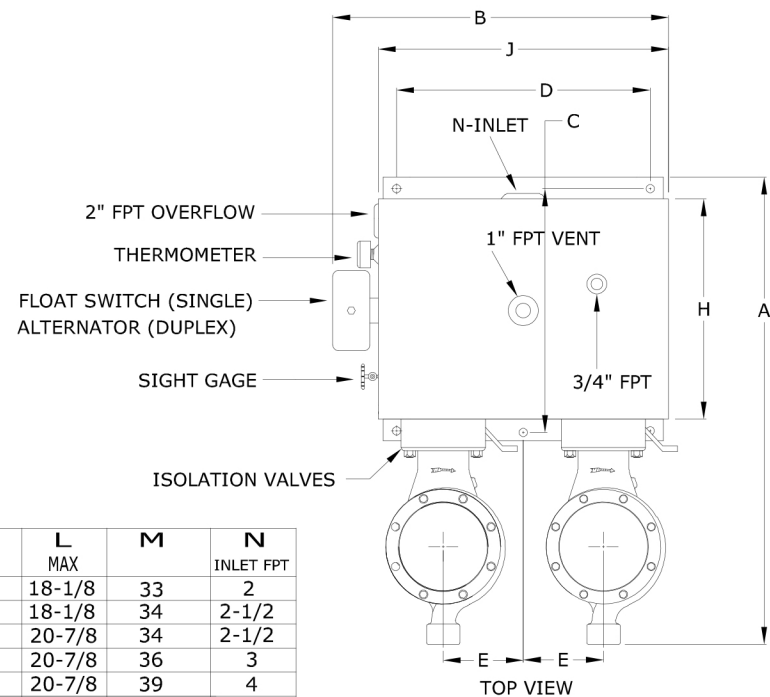
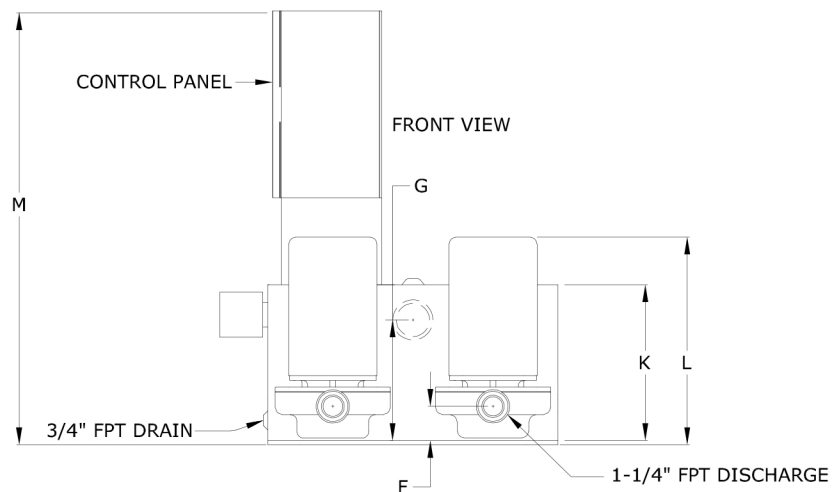

DIMENSIONS ARE INCHES

MODEL	RECEIVER CAPACITY U.S. GALLON	A	B	C	D	E	F	G	H	J	K	L MAX	M	N INLET FPT
10 GALLON	10	33	23-1/8	16-13/32	15	N/A	2-15/16	7-5/8	14	17	11	18-1/8	33	2
15 GALLON	15	35	27-1/8	18-1/4	19	6	2-15/16	9-3/8	16	21	12	18-1/8	34	2-1/2
30 GALLON	30	46	27-1/8	28-1/4	19	6	2-15/16	10	26	21	12	20-7/8	34	2-1/2
45 GALLON	45	46	38-1/8	29-1/4	30	11-1/2	2-15/16	11	27	32	14	20-7/8	36	3
75 GALLON	75	55	38-1/8	37-1/4	30	11-1/2	2-15/16	13-1/2	35	32	17	20-7/8	39	4
95 GALLON	95	46	41-1/8	37-1/4	33	13	2-15/16	14	35	35	17-3/4	20-7/8	40	4
120 GALLON	120	54	44-3/4	40-3/4	36-1/2	14-3/4	2-15/16	15-3/4	38-1/2	38-1/2	18-1/2	20-7/8	41	4

NOTES:

1. PUMP DISCHARGE, 1-1/4" FPT
2. ATMOSPHERIC VENT, 1" FPT
3. FOOT MOUNTING HOLES, 5/8" I.D.
4. RIGHT SIDE PUMP IS PROVIDED WHEN DUPLEX IS ORDERED
5. FOR UNITS ORDERED WITHOUT ISOLATION VALVES, SUBTRACT 3" FROM DIMENSION "A".